

Dividers

NEW WORLD ORIGAMI SERIES: Book 1
by Tomoko Fuse

NOTE: The dimensions for a square can be easily established by adding the width of the box + twice the height of the divider.

Divider A

1.

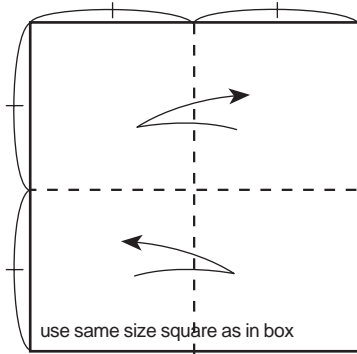

crease diagonal lines.

2.

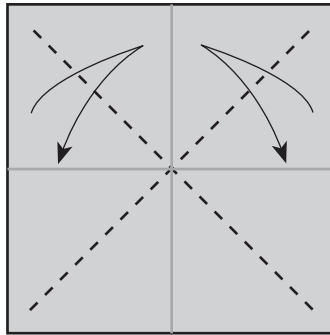

crease vertical and horizontal lines.

3.

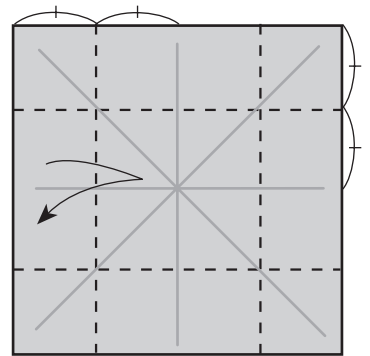

fold all the edges toward the center line and open.

4.

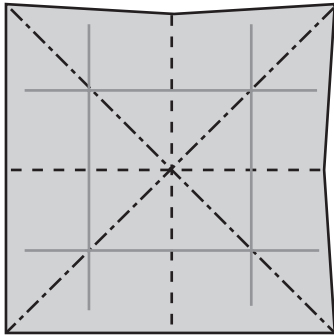

peak and valley fold, collapse into a triangle form.

5.

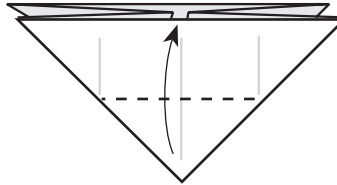

6.

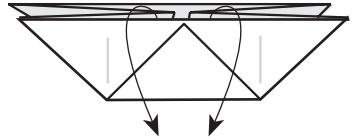

pull top layer down.

7.

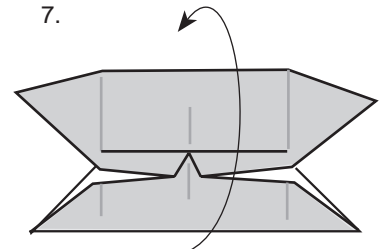

open and lay flat.

8.

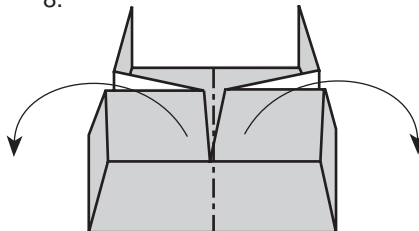

peak fold center line, moving sides downwards.

9.

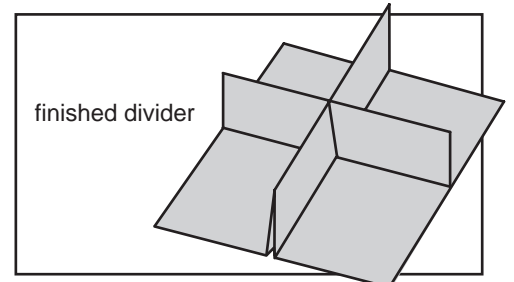
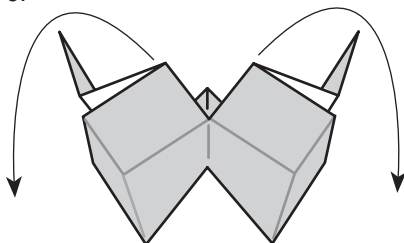

finished divider

Divider B

3b.

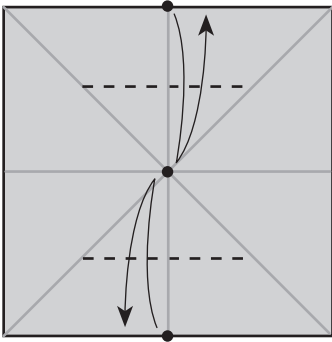

start from fig. 2 in divider A;
fold matching dots.

4b.

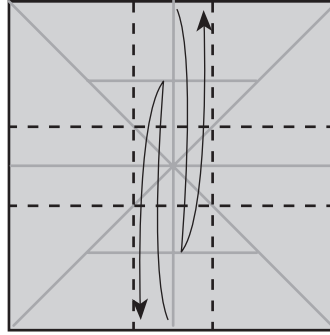

fold to marking crease in
both directions.

5b.

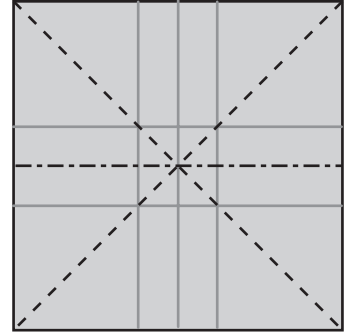

peak and valley fold, collapse
into a triangle form.

6b.

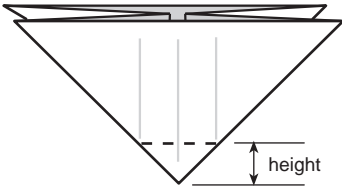

fold to the desired height
of divider and continue
from fig. 5 in divider A

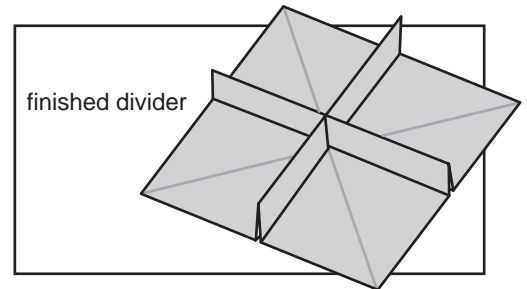

Divider C

3c.

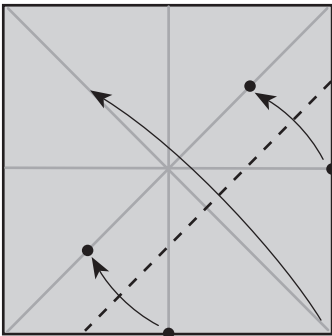

starting from fig. 2 in divider A,
fold matching dots.

4c.

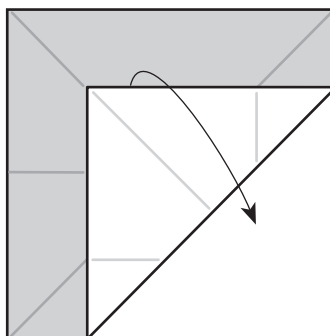

open.

5c.

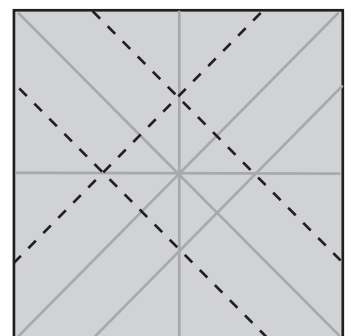

continue this fold in all
directions.

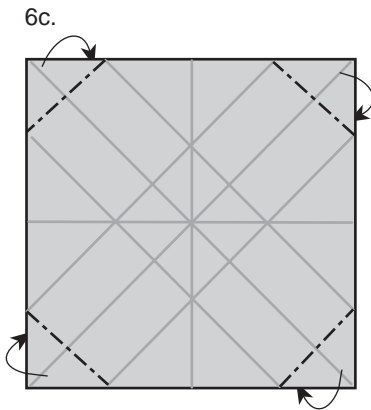

6c. peak fold.

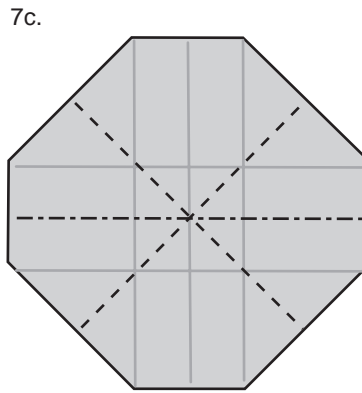
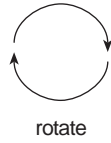

7c. collapse into a triangle form.

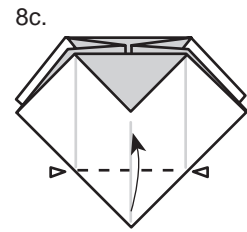

8c. fold up at crease marks.

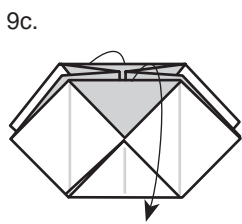

9c. pull top layer down.

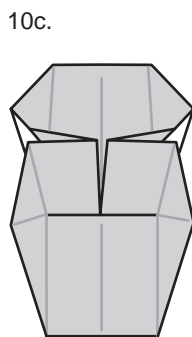

10c. open and lay flat.

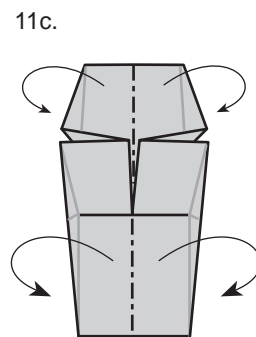

11c. peak fold center line, moving sides downwards.

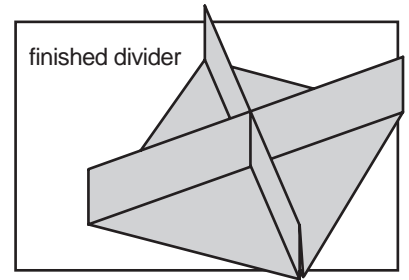

finished divider

Divider D

1.

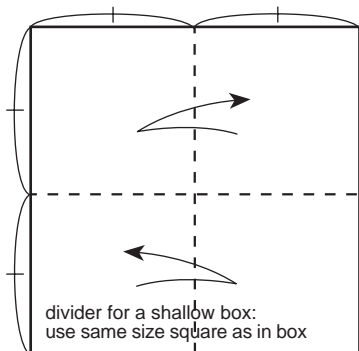

fold and open.

2.

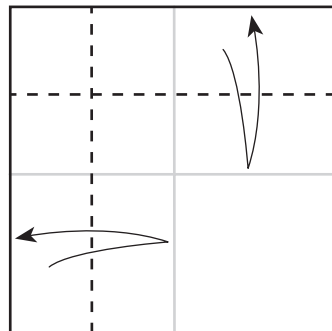

3.

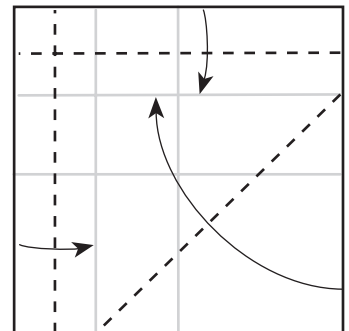

fold to crease lines.

divider for a shallow box:
use same size square as in box

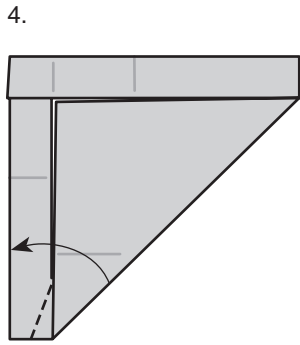

4. fold over, aligning edges.

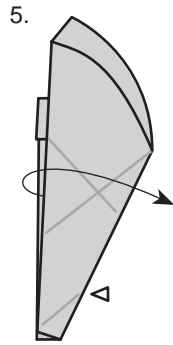

5. crease to arrow only.

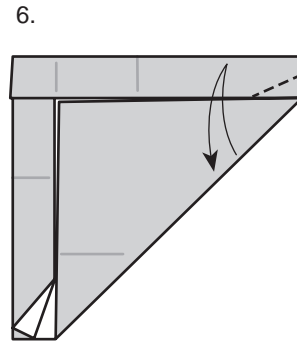

6. repeat fold, aligning edges.

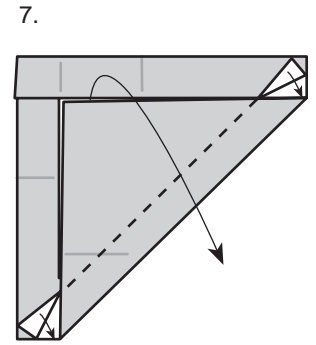

7. open and fold between marking creases.

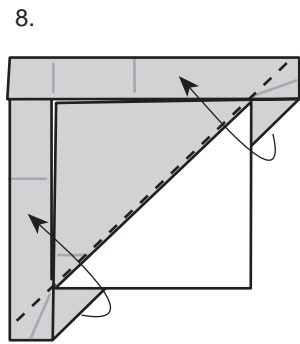

8. fold over.

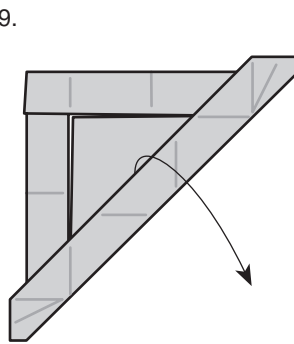

9. open.

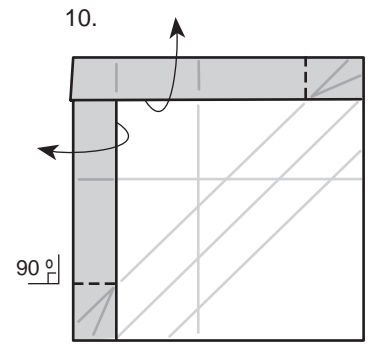

10. crease the corners at a right angle.

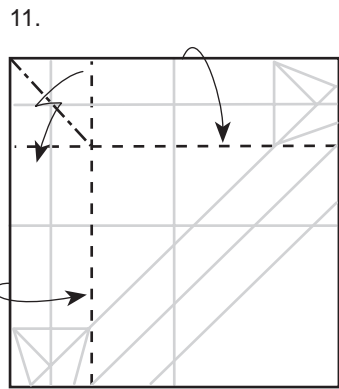

11. pleat fold corner, lift and fold in sides.

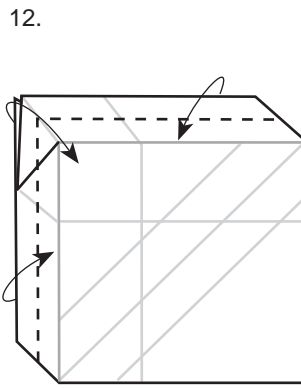

12. fold edge over sides.

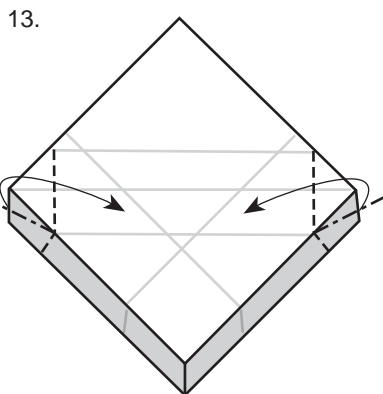

13. pleat fold ends to form corners.

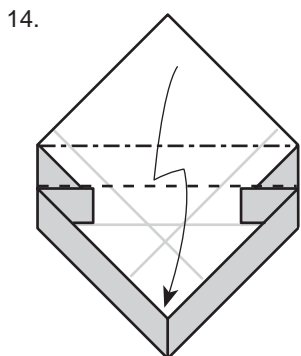

14. folder over side and form floor of box.

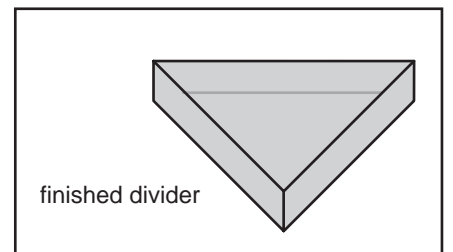

finished divider